



whitehorse  
general hospital



*A patient's guide  
to improving  
health*

**BEFORE, DURING & AFTER**

# Joint Replacement Surgery

## Acknowledgements

This booklet adapted from booklets:

“Your Total Hip Replacement” and “Your Total Knee Replacement” by The Physical Therapy Department of the Mary Pack Arthritis Program and The Reconstructive Orthopedic Health Care Team at Vancouver General Hospital. It has been adapted for use by Whitehorse General Hospital with the permission of the Fraser Health Authority and Vancouver Coastal Health Authority.



# Getting Ready for Surgery - A Checklist to Help You Prepare

As soon as you have seen your surgeon, begin working on the following - these activities may help to make the wait for surgery easier to bear:

- Read this booklet thoroughly
- Sign up for a fitness assessment and exercise program.
- Begin a healthy eating plan.
- Prepare your home for convenience and safety. See page 39.
- Consider who will be able to support you when you go home from the hospital. You will need someone readily available in your home for the first 72 hours and then for 10 to 14 days until you can move around more easily.

## Contact Family Doctor

- pain is affecting your sleep, mood, appetite or necessary activity.
- you have difficulty walking due to severe pain or unsteadiness.
- you are feeling depressed or sad for longer than two weeks.
- you are having difficulty with daily activities such as dressing, bathing and preparing food.

### **3 Months Prior to Surgery**

- Begin to make arrangements with your support person.
- Arrange to have a thorough check up with your family doctor. If you have any medical conditions, see your specialist to ensure that you are in the best possible shape.
- Have your hemoglobin checked. The goal is to have your hemoglobin in the high end of the normal range. Take any iron supplements or medications prescribed by your doctor. Pay special attention to iron rich foods in your diet. See page 36.

### **1 Week Prior to Surgery**

- Obtain all needed equipment & make sure they are properly installed. See pages 40.
- Pack equipment and clothing for hospital stay. Be sure to bring a cheque or credit card number to purchase your prescriptions.
- Call surgeon's office to confirm date & location of surgery.
- Ensure that someone will be available to support you at home.
- If you are leaving Whitehorse for your surgery be sure to let the surgeon's office know where you will be staying prior to your hospital admission.
- Be sure to take a walking aid with you.

### **1 Day Before Surgery**

- Remove all body & facial makeup, including nail polish on fingers and toes.
- Remove all jewellery. Your wedding ring may be covered with hospital tape
- Please shower the evening before surgery using special soap if provided.
- DO NOT have solid foods or fluids after midnight the night before surgery. This includes gum, candy, and water.
- DO NOT smoke after midnight

### **Packing Your Bag**

- "Before, During and After Joint Replacement Surgery" Booklet
- Toiletries
- Full set of clothing (loose fitting pants, top, socks, underwear)
- Knee length bathrobe (front opening)
- Non skid slippers and supportive shoes
- Small amount of money and/ or credit card.
- Take your walking aid to the hospital

## Pre-Surgery Self Screening-Risk/Action

The following are risk factors that may delay your recovery and prolong your hospital stay. Please review and take the recommended action.

RISK	ACTION
Pain interfering with sleep, necessary activities, appetite and mood.	See Pain Section page 25-31 Consult family doctor
Depression or consistently low mood	Consult family doctor
Low hemoglobin or tired/low blood	Consult family doctor
Medical conditions	Consult family doctor or specialist
Problems walking safely	See pages 39, 71, 77, 81, 84, 85, 91
Problems carrying out necessary daily activities	See pages 63-72, 76
No one available to assist you at home after surgery	See pages 38, 76
Difficulty arranging needed equipment after surgery	See pages 40, 77, 81, 83, 84, 85, 91
Poor home set up for example, many stairs	See pages 38, 71, 77. Contact community health centre or family doctor.
Regular alcohol, tobacco or other substance use	Consult family doctor or specialist

# A patient's guide to improving health

<b>Joint Replacement Surgery .....</b>	<b>1</b>
Getting Ready for Surgery - A Checklist to Help You Prepare	1
Contact Family Doctor	1
3 Months Prior to Surgery	2
1 Week Prior to Surgery	2
1 Day Before Surgery	2
Packing Your Bag	2
Pre-Surgery Self Screening-Risk/Action	3
Introduction	7
About Joint Replacement Surgery	8
Revision (Repeat) Joint Replacement Surgery	8
<b>Hip Replacement.....</b>	<b>9</b>
Types of Hip Replacements	11
Hip Precautions	14
Things You Can Do	15
<b>Knee Replacement .....</b>	<b>17</b>
Types of Knee Replacement	20
Knee Precautions	21
Things You Can Do	22
<b>Pain Control .....</b>	<b>23</b>
Pain Control	25
Pain Management for People Undergoing Total Joint Surgery	25
Types of Pain	25
Addiction Concerns	26
Reporting Pain	27
Short-Term Relief	28
Medications	28
Side Effects	29
Pain Relief Strategies	30

<b>Before your Joint Surgery .....</b>	<b>33</b>
Get Your Body in Shape	35
Exercise	35
Healthy Eating for Healing	36
Weight Loss	37
Arrange Home Supports	38
Home Setup	39
Equipment	40
Getting Ready for Surgery Checklist	40
<b>Complications How to Prevent them .....</b>	<b>43</b>
Complications	45
Low Blood (Anemia)	45
Harmful Blood Clots	46
Preventing Lung Complications	47
Delirium After Surgery	47
Infection	48
Dislocation After Hip Replacement	49
Loosening and Wear	49
<b>During your hospital stay .....</b>	<b>51</b>
What to Expect While You are in Hospital	53
While You are on the Surgical Ward	53
Exercise	55
Pain Control	55
Diet	56
Preparing to go Home	56
<b>After Caring for yourself at Home.....</b>	<b>57</b>
Care of Your Incision	59
Managing Pain	60
Physiotherapy	62
General Therapy Guidelines	62
Daily Activity Guidelines	63
Living With Your New Joint	69
Avoiding Falls	71
Driving a Car	71
Airport Metal Detecting Devices	72
Pregnancy	72
<b>Yukon Resources .....</b>	<b>73</b>
<b>Walking with Crutches/Canes or a Walker .....</b>	<b>93</b>



# Introduction

Research shows that people who are well prepared and fully participate in their care have a smoother and faster recovery after joint replacement surgery. Preparing for surgery involves getting yourself and your home in the best possible shape before surgery. During the long wait for surgery, it is important that you strive to maintain and improve your health and fitness. The purpose of this book is to describe what you can do before, during and after surgery so that your joint replacement is as successful as possible.

Joint replacement is a major surgery that needs a great deal of hard work and healing on your part. You play a key role in preparing for a successful surgery and recovery. You are training for a major physical event and the health care team are your coaches.

Hospital stays are short. In general, your home is a healthier place to recover. People tend to eat, sleep and heal better at home. The length of stay in hospital depends upon the type of surgery and recovery. Some people now go home the day of surgery. Most people go home two or three days after their surgery with the help of family or friends. Some people stay longer due to health problems. The role of the health care team in hospital is to get you moving and back to your daily activities safely, as soon as possible.

Review and follow the guidelines in this book carefully before, during and after your hospital stay to get you and your home in the best possible shape for surgery and recovery. Remember to bring this book with you to the hospital.

If there is a difference between this book and instructions from your surgeon, family doctor or orthopedic team, follow the instructions specific to you from the surgeon/doctor/team.

## About Joint Replacement Surgery

Joint replacement surgery is one of the most important and consistently successful orthopedic procedures in surgery today.

The most common causes of joint disease are osteoarthritis,, rheumatoid arthritis, and avascular necrosis (death of the bone due to lack of blood supply). Joint replacement surgery is considered only for those people with severely damaged joints who can no longer be helped sufficiently by other means, such as exercise, weight control, medications etc. Joint replacement surgery may:

- relieve pain (the main reason for most people)
- improve joint motion
- correct deformity
- improve function such as walking, standing, dressing, bathing, etc...

More than 90%\* of people have good to excellent results after a first joint replacement. The life expectancy of the implant is difficult to predict but is generally thought to be 15 to 20 years.\* The more stress you place on your joint, the faster your new joint may wear out. After this time, a revision procedure is usually needed due to “wearing out” of the components.

There are many types of joint replacement surgeries and some are only suitable for certain people. The best surgery for you is decided with your surgeon based on: your age, how strong your bone is, the shape and condition of your joint, your general health, your weight and activity level.

### Revision (Repeat) Joint Replacement Surgery

If for any reason joint replacement surgery fails, revision surgery may be necessary. In revision surgery, the original joint replacement components are removed and replaced with new ones. Revision surgeries are more complex and may not last as long as first joint replacements. Failure can occur for many reasons including repeated dislocations, loosening and wear of the new joint, bone loss and infection. Sometimes the joint fails when too much stress is placed on it over time. It is extremely important to follow the long term precautions to protect your joint – see pages 69-71.

# Hip Replacement

Types of Replacement

Hip Precautions

Things You Can Do



## Types of Hip Replacements

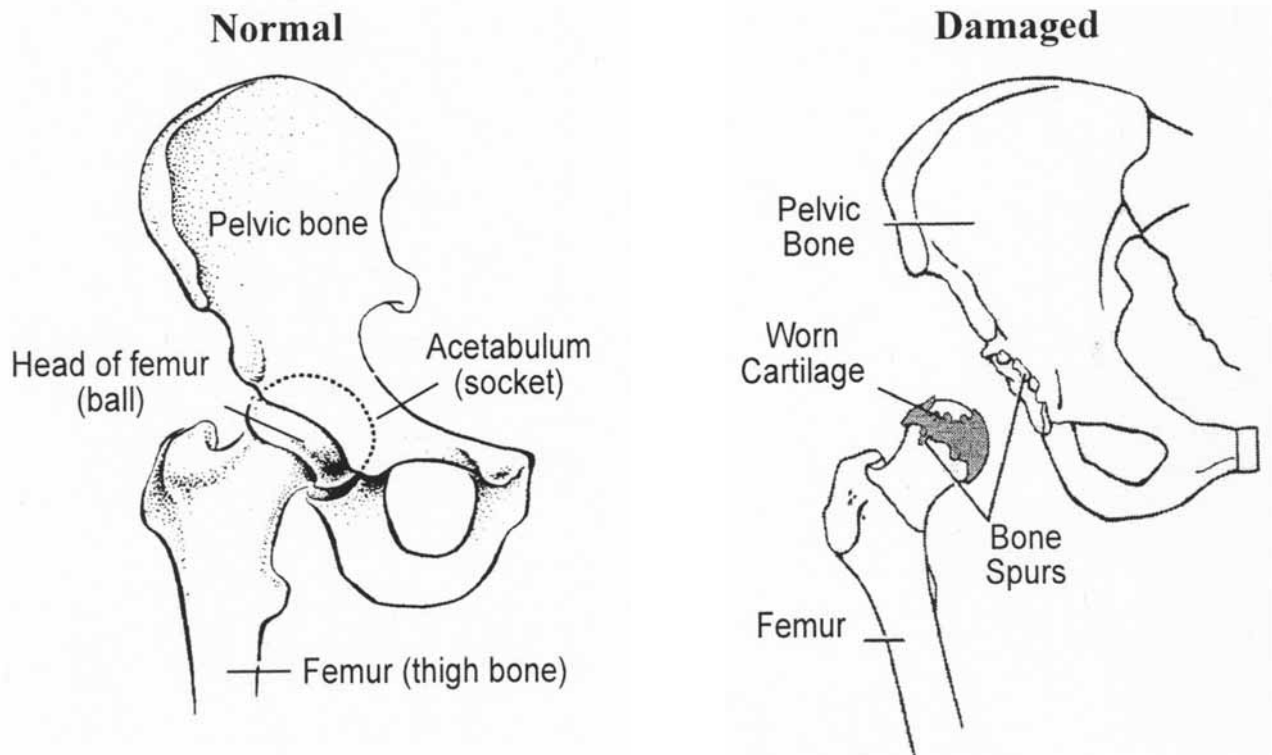

### Total hip replacement

(THR) (also called total hip arthroplasty, THA) consists of two parts.

1. **Femoral (ball and stem) component** the ball and stem fits into the femur or thigh bone.
2. **Acetabular (socket) component** - the acetabular component fits into the socket in the pelvic bone.
3. The femoral component fits into the acetabular component.

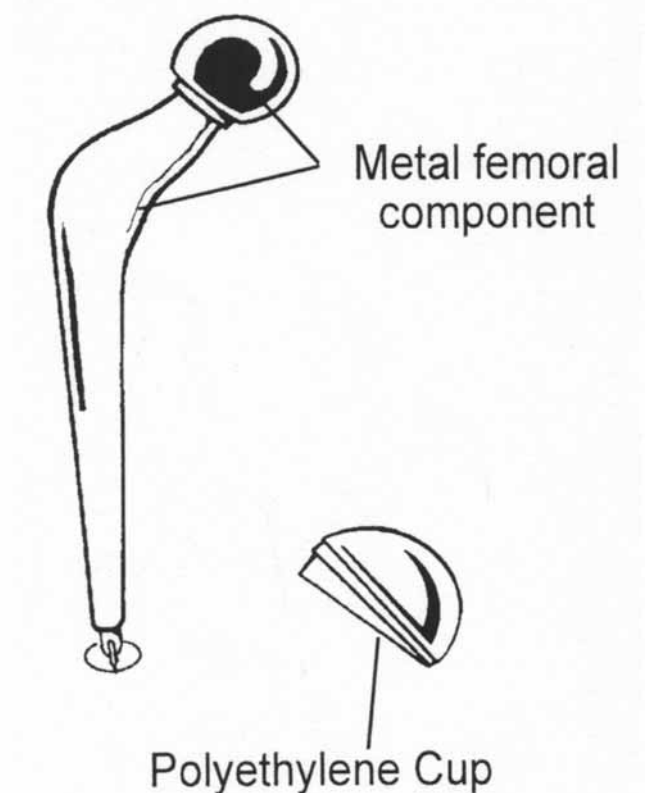

## The Surgical Procedure for Total Hip Replacement

The incision is usually made over the top of the femur (thigh bone). The muscles that hold the hip in place are partially detached.

The ball of the femur is then removed from the acetabulum (pelvic socket). The damaged cartilage and bone are cleaned away. The new socket cup is then fixed in place in the pelvic socket.

The head (ball) at the end of the femur (thigh bone) is then removed. Some bone marrow is removed from the hollow of the femur so that the metal stem can be placed.

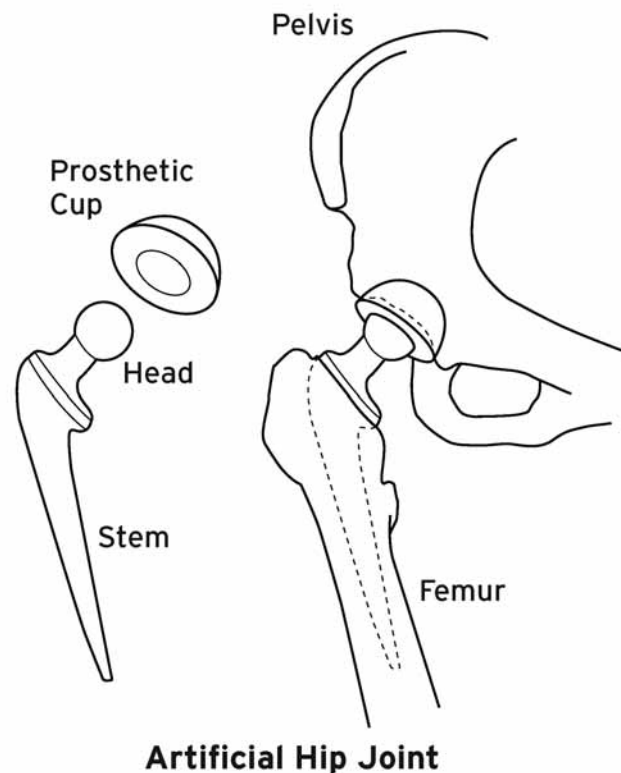
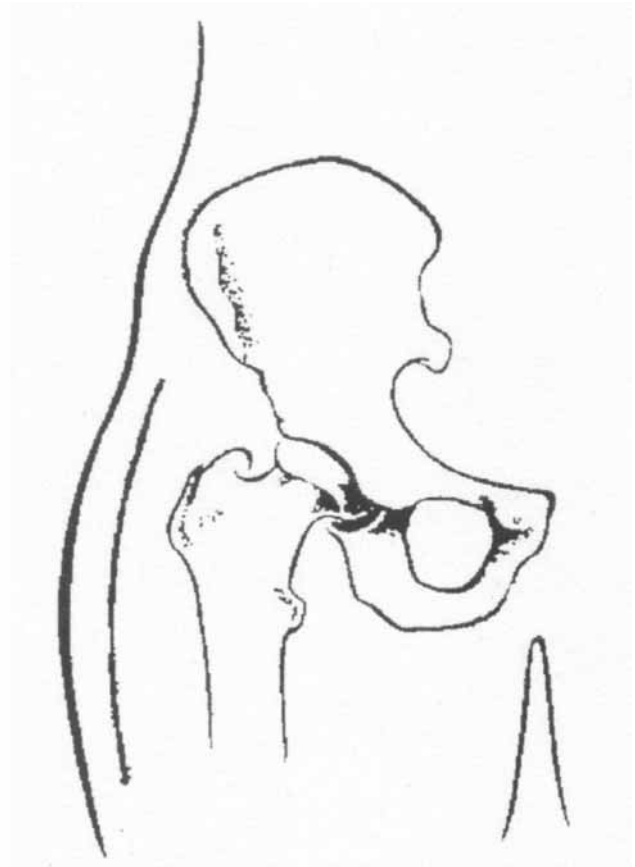

The new hip is put together and the muscles and skin are sewn in place with sutures and or staples. The hip is then tested for movement and stability. The surgery usually takes about 1.5 hours.



**There are two ways in which your joint replacement may be held in place:**

- 1) with bone cement, or
- 2) by having your bone grow into it.

**In Cemented or Hybrid Joints**

One or both components are held in place by a special bone cement (methyl methacrylate). This cement is pressed into the small nooks and crannies of the bone to form a bond between the metal and the bone. The cement hardens immediately allowing early weight bearing and walking after surgery.

**Uncemented (“porous coated”) joints**

In an uncemented replacement, the components are coated with thousands of tiny beads. These beads provide a huge network of nooks and crannies into which new bone can grow. This provides a direct bone to metal bond without cement. The new bone takes 6-12 weeks to grow and it may be necessary to protect the growing bone. For this reason, you may need to keep your weight off the new joint and use crutches or a walker while you are healing.

## Hip Precautions

- for 12 weeks post surgery

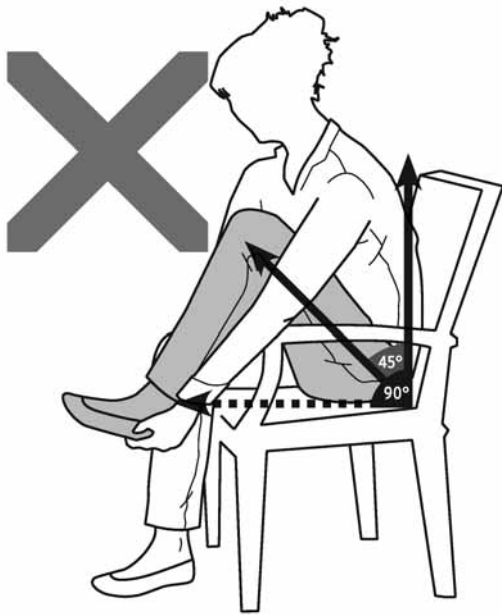

**DO NOT** bend your hip past 90 degrees



**DO NOT** cross your legs at the ankles or knees



**DO NOT** twist your body or legs

The muscles around the hip take time to heal and get strong so your hip won't dislocate. You must keep using these precautions for 12 weeks after your surgery.

## Things You Can Do

Some people use their raised toilet seat and seat cushion indefinitely. **DO sit on a raised chair or use a high-density foam cushion to increase surface heights. Use a raised toilet seat.** (see page 63 for how to sit)



**DO use long-handled aids, such as a shoehorn and reacher, to help you dress and pick up items.**

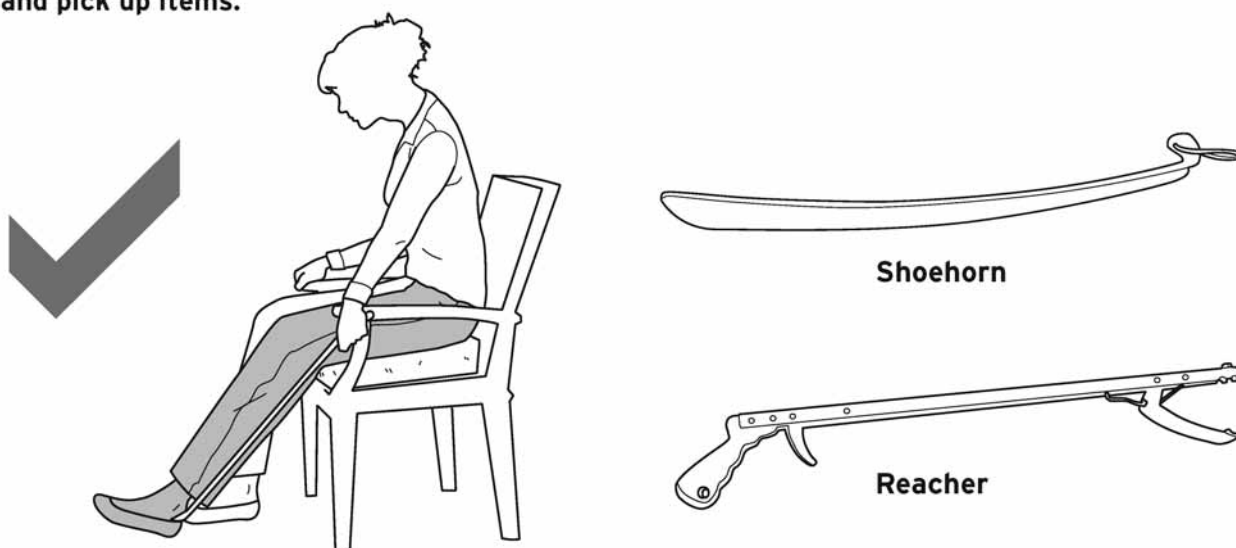

**DO sleep with pillows between your legs for the first 3 months after surgery.** You may require assistance placing the pillows or choose to use an extra-long pillow.

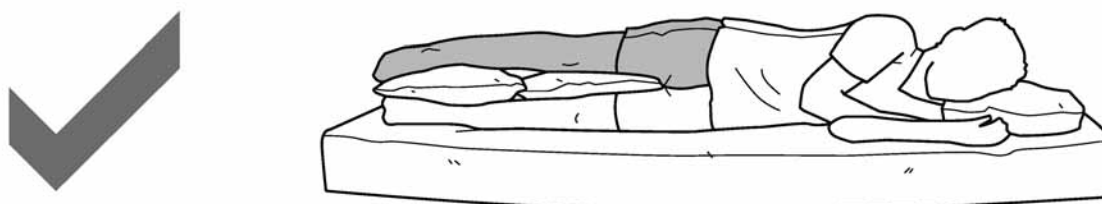



# Knee Replacement

Types of Knee Replacement

Knee Precautions

Things You Can Do



# Knee Replacement Surgery

In knee replacement surgery, the damaged bone and cartilage are replaced with metal and plastic surfaces that are shaped to restore knee movement and function. The new artificial knee is called a prosthesis. Stainless steel, cobalt, chrome alloys or titanium may be used for these components. Durable, wear resistant polyethylene (plastic) is used for the weight bearing surface. Bone cement may be used to anchor the prosthesis into the bone. Some knee replacements may also be implanted without cement where the bone grows directly into the implant.

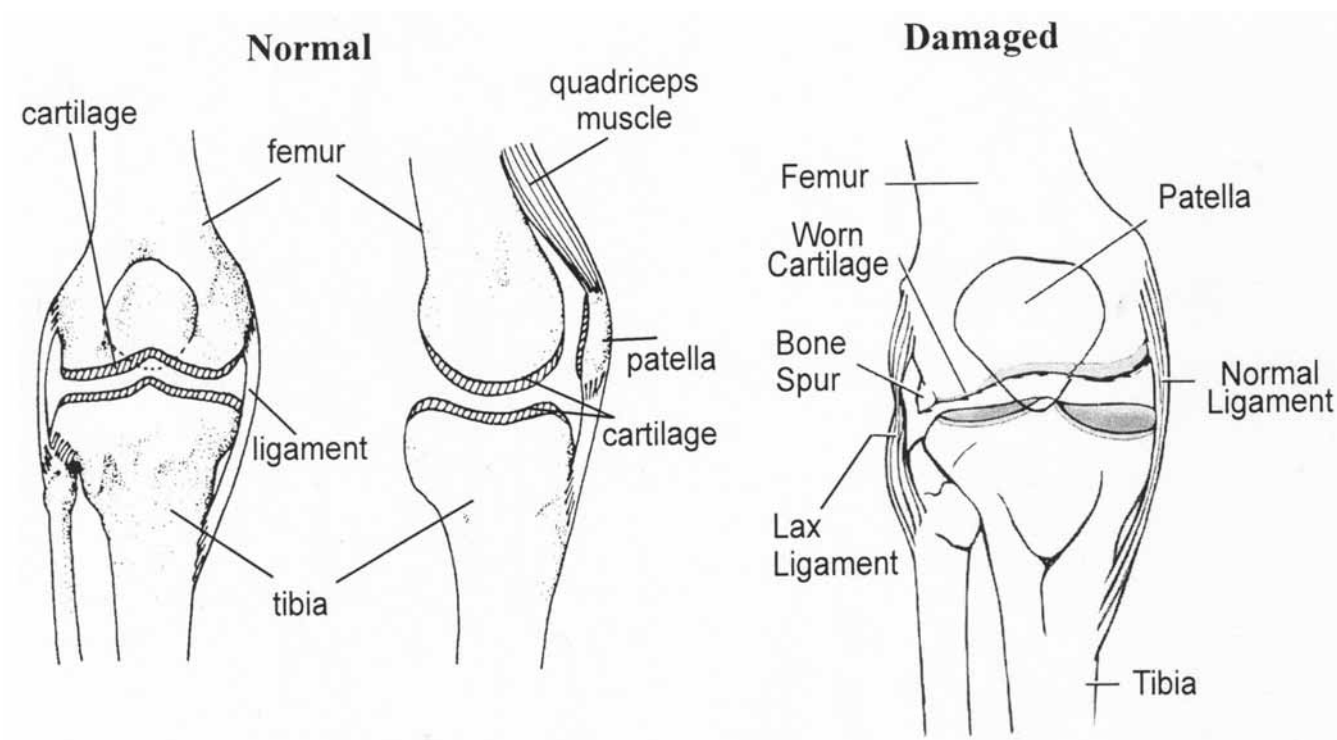

## Types of Knee Replacement

(TKR) (also called total knee arthroplasty, TKA) consists of three parts:

**1. Femoral (thigh bone) Component** - metal piece replaces the weight-bearing surface of the femur and has a groove in which the patella (knee cap) moves.

**2. Tibial (shin bone) Component** - metal and polyethylene (plastic) component fit onto the tibia and form a smooth surface upon which the upper metal component can glide during movement of the knee joint.

**3. Patellar (knee cap) Component** - a polyethylene (plastic) button is attached to the back of the patella to provide movement between it and the groove in the upper femoral component.

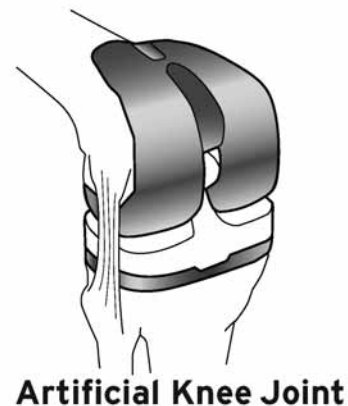
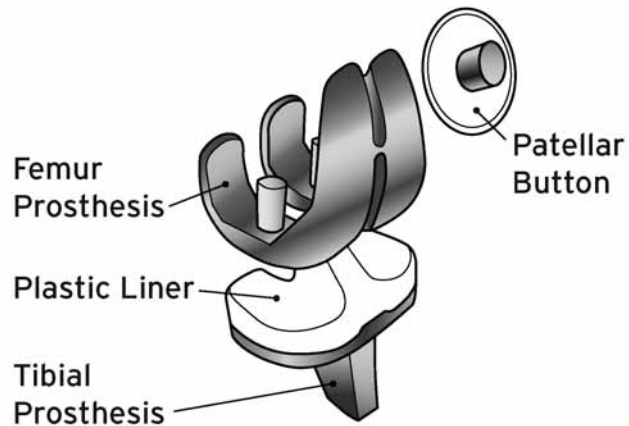

## Unicompartmental Knee Replacement Surgery

When only the inside part of the knee joint is damaged, it may be possible to replace just this part of the joint. The procedure is similar to a total knee replacement, but only one side of the joint is resurfaced. Recovery time is generally slightly shorter after this kind of surgery.

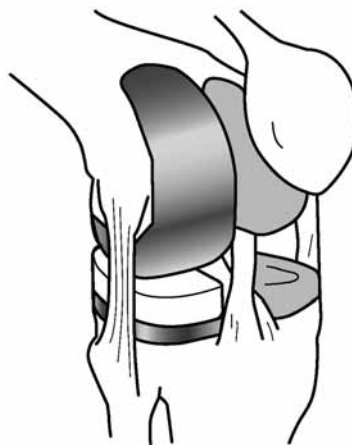

**Partial Artificial  
Knee Joint**

## Knee Precautions - for 12 weeks post surgery

12 weeks

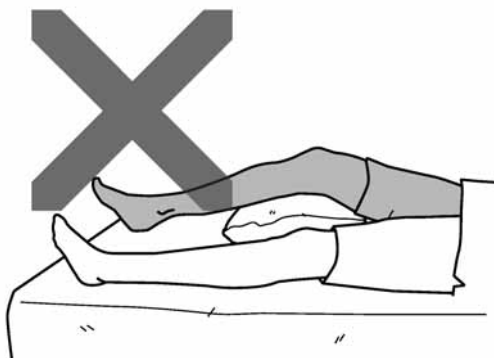

**DO NOT** put a pillow behind your knee.  
Your knee may become stiff if you keep it bent.

minimum of 12 weeks



**DO NOT** kneel on your new knee joint

never

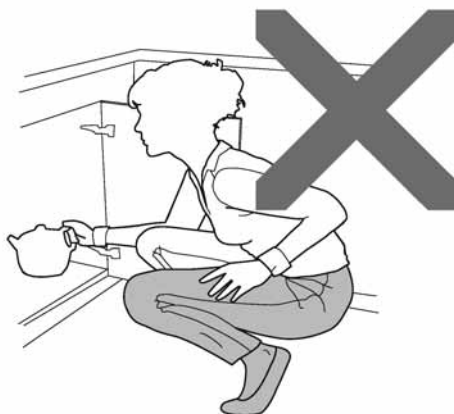

**DO NOT** do deep squats (squatting down to the floor.)

## Things You Can Do

**DO sit on a raised chair or use a cushion.** It will be easier to get on and off higher surfaces after surgery. Consider using a raised toilet seat.



**DO use long-handled aids, like a shoehorn and reacher, to help you get dressed or pick up items.**



**Shoehorn**

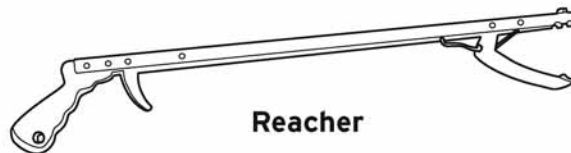

**Reacher**

# Pain Control

Pain Control

Addiction Concerns

Reporting Pain

Short Term Relief

Medications

Side Effects

Pain Relief Strategies



# Pain Control

## Pain Management for People Undergoing Total Joint Surgery

Pain not only affects your enjoyment of life and ability to carry out your desired activities, it is also a stress on your physical and mental health. Research shows that people who have ongoing pain are more prone to infection, depression and poor health. The ongoing pain that you have from your joint disease is not healthy and needs to be managed. The following guidelines will help you better manage your pain before and after your surgery. **If these guidelines differ from the advice of your doctor, follow the advice of your doctor!**

## Types of Pain

**Osteoarthritis (OA)** is a disease of wear and breakdown of the joint cartilage. As the cartilage wears away, the bone beneath it becomes damaged. The joint becomes painful, stiff and deformed. Although each person is unique, aching and stiffness are the words commonly used to describe the pain.

**Rheumatoid Arthritis (RA)** is an inflammatory disease that affects the lining of the joints and sometimes the skin, eyes and other organs. The classic signs are pain, tenderness, swelling, stiffness and loss of function. Pain in rheumatoid arthritis is caused by inflammation, the destruction of cartilage and bone in the joint and sometimes irritation of the nerves. People typically complain of aching, throbbing, stiffness, warmth and tenderness.

**Surgical Pain:** Pain after surgery results from the incision into the skin, muscles and bones as well as movement of these tissues that is necessary to do the operation. The pain related to your surgery is worse in the first few days and will gradually subside six weeks to three months after your surgery.

## Addiction Concerns

Some people don't take necessary pain medication because they worry needlessly about becoming addicted. Research shows that addiction is very, very rare in people taking pain medication for painful conditions. People with severe pain take medication to get relief from pain and stop taking medication when the pain improves. People with addictions on the other hand, take certain medication for the sole purpose of getting high. Sometimes people confuse addiction with **physical dependence** and **tolerance**. These are not the same as addiction.

**Physical Dependence:** Over time, the body adapts to certain pain medication after continued use. When the medication is stopped suddenly, the person may experience withdrawal symptoms such as headache, sweating and nausea. These symptoms can be prevented by slowly reducing the dose of the drug over time, rather than stopping it suddenly.

**Tolerance:** Over time the body may need more of the pain medication to get the same effect. Medication doses may need to be adjusted with your doctor to get the best pain relief. If you have a history of addiction to alcohol or drugs talk to your doctor about this.

## Reporting Pain

In order to get the best possible treatment, it is important to communicate your pain so that health care providers fully understand the type of pain you are having. A common way to measure how bad your pain is, is to rate the pain on a scale from 0 to 10. Zero means no pain and 10 is the worst possible pain you can imagine.

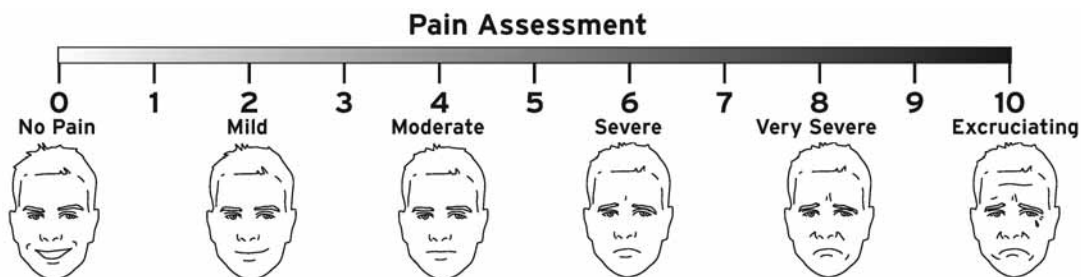

It is also helpful to use words to describe the pain and its specific location. Words such as 'bad, bothersome, and terrible' do not describe the pain very clearly. Words that are more specific such as: **aching, burning, stinging, or throbbing** help the health care team to better understand the nature of your pain and to select the best treatment.

## Short-Term Relief

### Medications

**Safe and effective control of your pain needs a partnership with your family doctor or arthritis specialist. Please talk to your doctor before using these guidelines.** People are unique in the pain control methods that work best for them. It may be necessary to try different medications and doses to find the one that works best for you. It is very important to follow all directions provided by your doctor, nurse or pharmacist.

The most commonly recommended medication for mild osteoarthritis pain is acetaminophen (Tylenol) taken regularly each day – for example two tablets taken up to four times during the day. People with liver, kidney or other health problems may be at risk for complications from this medication and should take a lower dose with advice from a doctor.

If Tylenol does not provide good pain relief, then anti-inflammatory medications could be tried. People with kidney problems or high blood pressure may be at risk for complications from this medication and should consult a doctor.

Newer anti-inflammatories are on the market and may have fewer side effects. Traditional anti-inflammatories such as Naproxen, Indomethacin, Indocid, Voltaren and Arthrotec work well for some people. Caution should be used with all anti-inflammatory medications including Celebrex because they may upset your stomach and cause bleeding from your stomach or bowel. Taking anti-inflammatory medications with food may help to reduce stomach upset. Misoprostal, a medication designed to protect the stomach lining may help to avoid bleeding if you are taking these medications regularly. **If there are any signs of bleeding in your stool or vomit, stop taking this medication and inform your family doctor right away.**

Anti-inflammatory medications and Tylenol can be taken together. Over time, the anti-inflammatory medications may stop working.

For people who continue to have severe pain after trying these medications, stronger medications such as Oxycodone, Dilaudid, or Morphine may be needed in addition to the Tylenol. Oxycontin, Hydromorphone Contin and Morphine Contin are long acting types of these drugs that offer pain relief for up to 12 hours. This may help you to sleep better. Some people find that Tylenol with Codeine (Tylenol #3) helps to keep the pain under control, however side effects with Codeine are more common than with other medications.

People who first start taking medications like Morphine, Oxycodone, Dilaudid or Codeine may experience drowsiness and nausea. Usually these side effects disappear within a few days. It is important to avoid activities that need concentration and good balance if you are feeling drowsy.

## **Side Effects**

**Constipation** is the biggest problem for people taking Oxycodone, Dilaudid, Morphine, or Codeine. Take a preventive approach: drink plenty of fluids, eat a high fiber diet including bran and prunes and take laxatives as needed. Fiber supplements such as Fruit Lax or 'Get up and Go Cookies' bulk up the stool making it easier to pass through the bowels. Senna tea, Senakot tablets or Glysennid tablets help the stool move along through the bowel. Glycerine or Dulcolax suppositories will help to clear the lower bowel. Ask your doctor, nurse or pharmacist if you have questions.

**It is important to follow instructions for your medications carefully to avoid side effects.**

## Pain Relief Strategies

**Arthritis Exercise Programs** - A program specifically designed to help you build strength, flexibility and to improve your mobility may help you to control your pain. Contact the Arthritis Society, your doctor, a rehab therapist (occupational therapist or physiotherapist), or local community center for assistance/information.

**Talk to an Occupational Therapist or a Physiotherapist** - These professionals may help you to select and use equipment to help you move, walk and do your activities of daily living more comfortably. A consultation can be arranged through your family doctor or by contacting a private clinic.

**Relaxation exercises and imagery** - Relaxation exercises and imagery may help you to rest and sleep and may also distract you from the pain.

**Heat and cold** - The decision to use either heat or cold for arthritis pain depends on the type of arthritis and should be discussed with your doctor or therapist.

An ice pack (or a bag of frozen vegetables) wrapped in a damp towel and placed on the sore area for about 15 minutes may help to reduce swelling and stop the pain. If you have poor circulation or altered sensation, do not use cold packs.

Moist heat, such as a warm bath or shower, or dry heat, such as a heating pad, placed on the painful area of the joint for about 15 minutes may help to relieve the pain. Heat may not be appropriate after surgery so consult with your doctor or rehab therapist before using it. Caution should be used if you have poor circulation or altered sensation.

**Joint Protection** - Using a splint or a brace allows joints to rest and protects them from further injury. Your doctor, occupational or physical therapist may assist you with this.

**Massage** - A massage therapist will lightly stroke and/or knead the painful muscle. This may increase blood flow and bring warmth to a stressed area. Arthritis-stressed joints are very sensitive so it is important that the therapist is familiar with this disease.

## Summary of Key Points

- Work with your doctor to find the medicine(s) and doses that work best for you.
- For ongoing pain, take acetaminophen and anti-inflammatory medications on a regular basis.
- If acetaminophen or anti-inflammatory medications do not relieve the pain, you may need a stronger medication such as Oxycodone, Dilaudid, Morphine or Codeine. Start with a low dose and take as needed. These medications may be taken along with acetaminophen or anti-inflammatory medications.
- If you have trouble sleeping, ask for a long acting pain medicine.
- Use caution when taking medications that cause drowsiness.
- Prevent constipation.
- Try using exercise, relaxation, imagery, cold, heat or massage in addition to medications.



# Before your Joint Surgery

Get Your Body in Shape

Exercise

Healthy Eating for Healing

Weight Loss

Arrange Home Supports

Home Setup

Equipment

Getting Ready for Surgery Checklist



## Get Your Body in Shape

To speed your recovery, it is important to get in the best physical shape possible for your surgery. While on the wait-list for your surgery, focus on building your strength and **staying as active as you possibly can!**

### Exercise

Choose low-impact activities such as walking (use good shock-absorbing shoes), swimming, water aerobics, stationary cycling, or chair aerobics. If exercising is new to you, **consult your family doctor to make sure that there are no associated health concerns before starting a new exercise program.**

**Avoid activities which significantly increase the pressure in your damaged joints** such as using a stair-master, jogging or intense hiking. As much as possible your activities should be pain-free. Throw away the slogan “no pain no gain” but keep the slogan **“use it - or lose it”!** If your arthritis is severe and you are often in pain, you may only be able to exercise in water or perhaps not at all. If you have pain for more than 2 hours after an activity or exercise session, you have done too much. Reduce the intensity of the exercise or the duration of the activity.

You will need to rely more on your arm strength to help move yourself around in and out of bed on those first few days after surgery. See a physical therapist in your community, talk to a fitness trainer in your local gym, or find a workshop that teaches people with arthritis how to lift weights.

Another option is to find an armchair exercise video which concentrates on upper body strengthening, while resting the lower body.

Check out the Canada Games Center (667-4386 or [www.canadagamescenter.ca](http://www.canadagamescenter.ca)) for land or water based fitness classes designed specifically for people with arthritis.

Even practicing walking (backwards, forwards, and sideways) in the water is beneficial as the water reduces the weight-bearing force on your joints and builds muscle strength.

The Arthritis Society has exercise programs for people and is an excellent resource.

Contact the Arthritis Answers Line at 1-800-321-1433.

The bottom line is to focus on getting as strong and fit as you possibly can.

## Healthy Eating for Healing

Healthy eating helps to prepare your body for surgery. Your body needs to be well nourished to heal the bones, muscles and skin that are affected by the surgery. The nutrients from food provide us with strength, energy and the ability to heal. People who are well nourished are less likely to develop infection.

In addition to adequate calories, there are several nutrients from food that are important to ensure adequate recovery from your surgery.

**Calcium** is needed to heal your bones and keep them strong. Good sources of calcium include: milk, yogurt, cheese, canned salmon and sardines (with the bones), and calcium-fortified tofu, soy and rice milk. Smaller amounts of calcium are also found in beans and lentils, broccoli, bok choy and oranges. Calcium-fortified food such as orange juice is also an excellent way to increase your dietary calcium.

**Protein** is needed to maintain/increase your strength and is necessary for healing after surgery. High protein foods include: beef, pork, fish and poultry, eggs, milk and dairy products, soy milk, beans, nuts, peanut butter, and tofu.

**Iron** is a very important nutrient that your body needs to build up the hemoglobin in your blood and prevent anemia. Hemoglobin carries oxygen throughout your body. If your hemoglobin level is low (anemia), you may feel tired, dizzy and weak or get short of breathe easily. You are more likely to need a blood transfusion after

your surgery. Good sources of iron include meat, fish and poultry, canned oysters and clams, beans, tofu, some green leafy vegetables, and fortified whole grains. However, the type of iron found in meat, fish and poultry is best used by your body. Eating foods rich in Vitamin C help the body absorb the iron found in non- meat iron rich foods. Examples of **Vitamin C** rich foods are: citrus fruits and juices, tomatoes and tomato products, cantaloupe, strawberries, and peppers.

**Vitamin B12 and folate** are also important nutrients to prevent certain types of anemia. Foods containing vitamin B12 include fish, meat, and poultry, milk and milk products and fortified breakfast cereals. Good sources of folate include leafy green vegetables, dry beans and peas, fortified grains and orange juice.

*Ask your family doctor to check your complete blood count (CBC) 3 months before you come to the hospital and follow up with the results of your test.*

Ideally, your hemoglobin level should be in the high end of the normal range. You may need to take an iron or additional vitamin supplement to bring your blood level up. **Eating well helps to ensure that you have a good hemoglobin level before surgery and may reduce the risk of requiring a blood transfusion after your surgery.**

### **Weight Loss**

**If you are carrying excess weight, talk to your doctor now about following a gradual weight loss program.** Extra weight can affect your recovery by slowing tissue healing, increasing fatigue and decreasing your activity tolerance. Gradual weight loss over a period of time is recommended. Keep in mind that “Crash Diets” can do more harm than good.

***1 EXTRA POUND  
= approximately  
3-6 POUNDS OF FORCE  
on your knees and hips***

By eating a well balanced diet, such as that recommended in “Canada’s Food Guide to Healthy Eating”, you are preparing yourself for a speedier and healthy recovery. If you are concerned that you have a poor appetite and do not get enough nutrients from your diet, seek advice from your doctor or a dietician about how you can improve your diet. It may also be helpful to add a daily multi-vitamin/mineral supplement and/or a high calorie, high protein liquid nutrition supplement. You can improve what you eat right now and there is help available to you.

For more information, contact your family doctor for a referral to a Registered Dietician. You can also visit the Dietician’s of Canada website for more information at [www.dietitians.ca](http://www.dietitians.ca).

## Arrange Home Supports

**Before you come into the hospital it is critical that you identify someone to be your support person to stay and help you at home after your surgery.**

Someone should be available to stay with you for at least the first 3 days after you go home and be readily available to you for 10 – 14 days after you come home from the hospital.

Many people need help with shopping, meal preparation, housekeeping, and sometimes personal care. You will also need to arrange for transportation home from the hospital. If you are having difficulty managing at home now, or are concerned about home support after your surgery, consult your family doctor.

*Preparing ahead of time will make your return home easier and safer for you.*

**If you already have homemaking services**, arrange to have these increased the first few weeks after surgery.

### Helpful Hints:

- Arrange for someone to look after your home while you are in the hospital. This may include watering plants, caring for pets and picking up mail.
- Cancel any services you do not need while in hospital such as newspaper delivery, homemaker services, etc.
- Discuss with your family or friends your transportation needs to and from the hospital. Make sure the vehicle has enough space to allow you to sit comfortably and safely in the passenger front seat.
- You may be eligible to use the Handy Bus (667-5774) for your transportation. See the Resources section at the back of this booklet for more information. To qualify, your doctor or therapist will verify that you have a disability that needs this service and you will have to fill out an application form.

## Home Setup

After surgery you will not be able to move and bend the way you normally do. For example, total hip patients must follow the movement precautions for at least 3 months.

You will be using a walker or crutches to get around. This will affect how you carry out everyday activities that most of us take for granted, such as getting up and down from a toilet, getting yourself dressed, and organizing meals. You need to be as safe as possible as you carry out the activities you need to do.

*There is a great deal you can do to get your home ready for your convenience and safety:*

- Install a railing along any stairs.
- Remove scatter rugs, cords, clutter and any thing that could cause you to trip.
- Remove all plants/other items from stairways.
- Remove ice and snow from outdoor steps.
- Make sure the inside of your home is well lit and use night lights particularly on the way to the bathroom.
- Install a grab bar or secure hand rail in your shower or bath.
- Be sure that your shower or tub has a non-slip coating or mat.
- Install a hand-held shower attachment for easier bathing.
- Reorganize cupboards/closets/fridge so items you use often are within safe reach.
- Buy frozen meals or prepare your own and freeze them for when you come home from the hospital. Stock up on canned food and other staples.
- Put a high stool for sitting in the kitchen for doing countertop activities.
- Add extra firm cushion to low chairs (chair should have a firm back and arm rests).
- Prepare a bedroom on the level of your kitchen and bathroom if possible.
- Check that the top of your bed's mattress is at least as high as your knee. Add another mattress or place the frame on blocks if it is too low.

# Equipment

In order to keep you safe and help you to carry out your daily activities you may need to obtain these assistive devices. This equipment is essential after hip replacement surgery and most people with knee replacement surgery also find these aids useful.

Your rehab therapist will instruct you on their use in your education class or in the hospital.

## How to Obtain Equipment

Medical supply stores have most of the equipment you need. The **Red Cross Medical Equipment Loan Service** in Whitehorse (456-7359) has a limited supply of equipment that can be lent to you free of charge for up to 3 months. You will need a referral from a medical professional to borrow equipment. It is staffed by volunteers and is open by appointment only. Call and leave a message. A volunteer will contact you to arrange a time to pick up equipment.

Pick up the equipment at least 3 weeks before your surgery so you can practice using it. See the Community Resource section at the back of this booklet for more information.

*Arranging these things at least 2 weeks in advance will prepare you for a safe recovery.*

You will be provided with a referral for Red Cross when you attend your pre-operative appointment at the Therapies Department at the Whitehorse General Hospital.

If you live in Whitehorse, the Yukon Homecare Program can arrange for a community therapist consultation or home visit to assess your particular needs and make equipment recommendations.

Contact Homecare at 667-5774.

If you live in a community, your community nursing station may have aides available. If not, a prescription for Red Cross can be mailed to you and you can call and arrange to pick up the equipment before you fly south for your surgery. If you are having surgery at WGH, the Red Cross loan service is located in the Thomson Center beside the hospital

## Getting Ready for Surgery Checklist

Please refer to the checklist provided at the front of this booklet to ensure you are prepared for your surgery

## Equipment List - Arrange up to 2 weeks before surgery.

### Equipment you MUST bring to HOSPITAL – unless otherwise told

#### Hip Surgery

- Walker
  - Standard OR  2-wheeled
- Crutches
- High-density (firm) foam cushion\* (at least 4 inch x 16 inch x 18 inch, needed for going home in the car)
- Dressing equipment (long handled reacher, long handled shoe horn and sock aid)

#### Knee Surgery

- Walker
  - Standard OR  2-wheeled
- Crutches
- Dressing equipment (long handled reacher, long handled shoe horn and sock aid) –  
OPTIONAL but recommended

### Equipment for HOME

#### Hip Surgery

The equipment below is **required**

- 4 inch raised toilet seat (with or without armrests)  
OR commode chair with wheels
- 26 inch long-handled reacher
- 24 inch long-handled shoehorn
- Sock aid
- 24 inch long-handled sponge\*
- Non-slip bathmat\*
- Elastic shoe laces\* (otherwise use slip-on shoes with an enclosed heel)
- Hand-held shower hose\*

Bathing – use a **walk-in shower:** OR **bathtub:**

Shower chair

Tub transfer bench OR

Raised shower board

Removable tub clamp  
OR installed grab bars\*

#### Knee Surgery

The equipment below is recommended

*\*Items NOT available at the Red Cross may be purchased at local medical supply stores.*



# Complications

## How to Prevent them

Low Blood (Anemia)

Harmful Blood Clots

Preventing Lung Complications

Delirium After Surgery

Infection

Dislocation After Hip Replacement

Loosening and Wear



# Complications

## - How to Prevent Them

Joint replacement is a major surgery and all surgeries come with a risk of complications. Complications may occur due to prior health problems, the anaesthetic, and normal surgery-related disruption to the muscles, nerves and blood vessels. There is a great deal you can do to prevent or lessen complications.

### **Low Blood (Anemia)**

You may lose a significant amount of blood during your joint replacement surgery. Blood loss can result in a drop in your hemoglobin – this is called anemia. Hemoglobin carries oxygen throughout your body. Hemoglobin can be measured with a blood test and has a broad normal range. For women the normal range is from 115 to 160 and for men it is from 135 to 175. Having your hemoglobin level at the high end of the normal range before surgery may reduce your risk of anemia after surgery. If your hemoglobin level is too low, you may feel dizzy and weak, short of breath, head achy, nauseous and very tired.

You may need a blood transfusion.

How you can help to prevent low blood and blood transfusion:

- Get your body in shape for surgery and healing - follow the recommendations for healthy eating on pages 36-37.
- Ask your family doctor to check your complete blood count (CBC) at least 3 months before you come to the hospital and follow up with the results of your test. Ideally, your hemoglobin level should be in the high end of the normal range.
- Consult your family doctor about the need for iron, or an additional vitamin supplement.
- There are some medications available that may help stimulate your bone marrow to produce more red blood cells. Your doctor will advise you if this would be helpful in your case.

## Harmful Blood Clots

Blood clots can develop in the deep veins during the first several weeks after surgery. People who already have problems with their heart or circulation, are inactive, overweight or have other health problems such as diabetes have a greater risk of developing these clots.

*Let your surgeon know before surgery if you have had a clot in the past.*

How you can help to prevent harmful clots after surgery:

- Get up and move frequently. Every hour, pump your feet and ankles. Every hour, tighten and release the muscles in your legs and buttocks.
- Wearing leg sleeves (sequential compression devices) while you are in bed in the hospital may be prescribed by your surgeon/doctor.
- Take the prescribed Low Molecular Weight Heparin (LMWH).

## More on LMWH (blood thinners)

Low molecular weight heparin (LMWH) helps to prevent harmful blood clots. Most people will need injections of a LMWH for 10-35 days after the day of surgery. The number of days you need this medication depends on your risk and is decided by your surgeon. The nurses in hospital will teach you or your support person how to inject this medication so you can manage at home.

You may need to pay for all or part of this medication depending on your drug plan.

*It is your responsibility to ensure that the prescription is filled. You will need to carefully read and follow all instructions for this medication.*

## Preventing Lung Complications

Lung complications such as fluid in the lungs or pneumonia may occur due to the anaesthetic and prolonged bed rest.

- Do not eat or drink after midnight on the night before your surgery.
- Get up and move, change your position in bed frequently.
- **Take 10 big deep breaths and cough every hour on the days after your surgery.**
- **Stop smoking.** People who smoke are at high risk for lung complications after surgery. Talk to your doctor about programs to help you stop smoking before your surgery.

## Delirium After Surgery

Sometimes older people go through a period of confusion or delirium after surgery. They may act or talk in ways that are not normal for them, for example, they may become forgetful, mixed up, and or see, hear and believe things that do not make sense. Delirium usually goes away in a few days but sometimes lingers for a few weeks. Delirium is usually due to more than one cause. Some common causes of delirium are: side effects of anesthetics and medications, lack of sleep, pain, infection, alcohol withdrawal, constipation and low oxygen levels. The health care team looks for and corrects the cause of the delirium whenever possible.

How you can help to prevent delirium

- Notify your nurse, surgeon or anaesthetist if you had delirium or confusion with a previous hospital admission.
- Wear your glasses and hearing aids.
- Get up and moving as soon as possible.
- If you drink alcohol on a regular basis, you may be at risk for delirium related to **alcohol withdrawal** while in the hospital. For six weeks prior to surgery limit your intake of alcoholic beverages to no more than one standard drink per day – 8 ounces of beer, 3 ounces of wine, or 1 ounce of spirits. Discuss any concerns about alcohol use with your family doctor.

## Infection

Less than 1% of patients develop a wound infection after surgery. However, when infection occurs, it is a very serious complication that may need long-term intravenous antibiotics and possible further surgery. Infections can start in your joint during surgery, in the hospital or when bacteria travel there from elsewhere in your body for example - from your throat, teeth, skin or urine. You are more likely to get an infection if you are not well nourished or if your immune system is not strong.

How you can help to prevent infection:

- Get your body in shape by eating healthy foods before and after your surgery (see pages 36-37).
- After surgery you will receive antibiotics through your intravenous.
- Wash your hands frequently.
- Follow the directions carefully for caring for your incision and changing your dressing (see page 59).
- Avoid people who have colds or infections.
- If you think you have any infection visit your doctor as soon as possible to see if you need antibiotics.
- Call your surgeon's office if your surgery is within a few days and you think you have an infection (e.g. fever, sore throat, infected cut, bladder infection, etc.).
- If you are having a medical procedure, dental fillings, or any major dental work, tell your doctor or dentist that you've had a joint replacement. You may need antibiotics before the procedure

## Dislocation After Hip Replacement

Dislocation happens when the components separate from one another or when the 'ball comes out of the socket'. After surgery, the muscles and ligaments that normally support your joint in place have been stretched and weakened by surgery and need time to heal. While healing, they are weak. Movements such as crossing your legs, bending forward, sitting in a low chair, twisting or stooping put too much pressure on these healing muscles and ligaments. The ball may then pop out of the socket. The signs of dislocation are sudden, sharp severe pain and a shortened leg. If dislocation occurs you will need to come into the hospital and have your hip put back in place under anaesthetic. After this you may need a cast or brace for six weeks.

How you can help to prevent dislocation:

- Carefully follow the activity guidelines and precautions pages 14, 63-71.
- Obtain and use the equipment prescribed for you by the rehab therapist. See pages 41 and 63-67.

## Loosening and Wear

Over time one or both of the components of the new joint may loosen. Loosening happens more quickly when the joint is used excessively or when the precautions are not followed carefully. A revision surgery is frequently needed when loosening occurs.

How you can help to prevent loosening and wear:

- Carefully follow the activity guidelines and precautions pages 14, 63-72 and 69-72.



# During your hospital stay

What to Expect While You are in Hospital

While You are on the Surgical Ward

Exercise

Pain Control

Diet

Preparing to go Home



Hospital stays are becoming shorter all the time with improved surgeries and the pressures on the health care system. The length of time you spend in hospital depends upon the type of joint replacement you have and your health after the surgery. **Some people go home as soon as the day after surgery, many go home by Day 3.** Those with serious health concerns may stay a little longer. **People tend to heal best and most safely at home.**

## What to Expect While You are in Hospital

When you come to the hospital on the day of your surgery, you will go to the same day admit unit. A nurse will greet you, assist you to change into a hospital gown and then will ask you questions about your health. You may also meet the doctor who will be giving your anaesthetic. An intravenous line (IV) will be inserted into your arm to allow the nurse to give you antibiotics and fluids.

After your surgery, you will wake up in the recovery room. The nurses there will observe you carefully, checking your blood pressure, breathing and circulation, until you are ready to go to the surgical ward.

## While You are on the Surgical Ward

- You will have an intravenous (IV) in your arm to give you fluids and medications. Antibiotics will be given to prevent infection. Your IV will be removed when your antibiotics are finished and you are eating and drinking well, usually the day after your surgery.
- Your nurses will be regularly checking your blood pressure, temperature, oxygen levels and the colour, warmth, movement and sensation of your operated leg.
- You may have a drain inserted into the operated leg after knee surgery.
- You may have blood taken for tests.
- You will have an injection of Low Molecular Weight Heparin (LMWH) to prevent blood clots. Your nurse will teach you or your support person how to inject the LMWH.
- It is possible that you may need a blood transfusion.

- It is possible that you may have a catheter to drain urine from your bladder if you are unable to pass urine after your surgery.
- Your nurses will remind or help you to change your position from your back to your non-operated side while in bed. This will prevent problems with your skin and will help your breathing. If you have a hip replacement, **ALWAYS KEEP PILLOWS BETWEEN YOUR LEGS WHILE IN BED** – for the next three months.
- The physiotherapist, nurse or occupational therapist may help you to sit on the side of your bed, stand and walk the day of surgery. You will continue to increase your mobility and learn to move independently.
- You may have leg sleeves on your legs to prevent blood clots.
- Your nurses will change your dressing and teach you how to care for your incisions.

You are ready to leave hospital when you:

- Are medically stable: your vital signs are normal, you are able to empty your bladder, you have no vomiting, or dizziness, your pain is controlled, and you are able to tolerate food.
- Able to manage daily activities without harming or dislocating your new joint e.g. dressing with essential garments, bathing, toileting, meals.
- Able to mobilize independently as necessary: i.e. can manage stairs if needed, can get into or out of bed.
- Able to tolerate sitting for short periods.

It is essential that you have organized the following before coming into hospital:

- transportation home.
- support person available for the first 3 days and then readily available for 10 days.
- Equipment and mobility aids to help you move around and safely carry out activities.
- Ready access to bedroom, bathroom and meals.

## Exercise

- Take at least 10 big deep breaths and cough every hour (while awake) to exercise and clear your lungs.
- Pump your ankles to improve circulation. Do this every time you think of it, at least every hour.
- Squeeze your thigh muscles. Hold for 6 seconds, then release. Squeeze your buttock muscles. Hold for 6 seconds, then release.
- Your rehab therapist will review your specific hospital and home exercise program.

## Pain Control

It is important that you take pain medication regularly while you have pain so that you are able to move and sleep. Your pain will be worse in the first few days, gradually subsiding over 6 weeks to 3 months. This will prevent complications and will help you heal. Pain medication may be given to you using one or more options including:

- 1) by mouth.
- 2) an epidural catheter (small tube) placed in your lower spine.
- 3) a patient controlled pain pump through your intravenous.
- 4) through a pain pump with a small tube into your surgical area.

If your pain medication is not working, please **tell your nurse**.

Constipation may be a problem after surgery so to prevent it, you will be given stool softeners and laxatives as needed when you are able to eat.

Review the pain management section on pages 23-30.

## Diet

After your surgery, you will begin drinking and then eating. You should try to eat. If you feel sick, please **tell your nurse** so that treatment can be provided.

## Preparing to go Home

Your team will make sure that you have arranged for someone to:

- Help you at home.
- Drive you home from the hospital.
- Pick up your prescriptions.

The rehab therapist will review the equipment and assistive devices that will help you to function safely with your day to day activities at home. This will happen on Day 1 or Day 2 after your surgery.

You will need to be confident in all activities you will perform at home including:

- walking
- getting around
- getting in and out of bed
- getting in and out of the tub/shower
- getting on and off the toilet
- getting dressed

The physiotherapist will practice walking and doing stairs with you to ensure that you are safe to manage at home. Follow-up physiotherapy will be discussed.

Before you leave hospital please ensure that you have: your belongings and your prescriptions for LMWH and pain medication.

# After Caring for yourself at Home

Care of Your Incision

Managing Pain

Physiotherapy

General Therapy Guidelines

General Activity Guidelines

Living With Your New Joint

Avoiding Falls

Driving a Car

Airport Metal Detecting Devices

Pregnancy



The following are some guidelines to help you recover safely and comfortably at home. If there is a difference between this information and specific information from your surgeon, family doctor or orthopedic team, follow the instructions specific to you from the surgeon/doctor/team.

## Care of Your Incision

Your incision may be exposed to air once there is no drainage. If you find it more comfortable, a strip dressing may be applied. These dressings can be bought at a drug store.

Look at your incision once a day for any redness or drainage. If you have steri-strips, leave them alone, as they will eventually fall off. If you have staples, they may be removed 10-14 days after your surgery. This usually happens in a follow up visit to your family doctor or by another qualified health care provider.

Keep the incision covered and dry while you shower. Once your staples are out you can get the incision wet. Pat the incision dry after showering and make sure that the incision is clean and dry at all times.

You may have a bath, go swimming or use a hot tub only when your staples or steri-strips are out, the **incision has completely closed and there is no drainage**. At the earliest, it will be at least 3 weeks post surgery and 1 week after your staples come out.

Your nurse will give you specific dressing instructions if you go home with a wound that still has drainage. It is important that the bandage is changed once a day (or more frequently if needed) until the drainage stops.

## Changing your dressing

Wash your hands and remove the old dressing, leaving small steri-strips over the incision intact. Clean the area around the incision with 2x2 gauze soaked in normal saline (can be bought at local drug store). Pat the area dry with a clean towel. Cover the incision/drain site with the dressings recommended by your nurse.

### Notify your family doctor or surgeon immediately if you have:

- Increased redness, bruising, drainage or swelling around the incision site.
- A foul odour or yellow or green drainage at the incision/drain site.
- Pain, redness or tenderness to the touch in the thigh or calf.
- A persistent increase in your temperature above 38°C or 101°F

## Managing Pain

Pain is the worst in the first few days and will gradually ease over 6 to 18 weeks. These are some ways to keep yourself comfortable.

### Take Pain Medication

- Follow the instructions provided with your medication and in the Pain Control section pages 25-31.
  - Do not wait until the pain is bad before you take pain medication. Try taking two extra-strength Tylenol tablets every four to six hours on a regular basis for the first few weeks at home. Do not take more than 8 tablets per day.
  - If you are taking Tylenol and your pain still affects your rest, activity, mood or appetite; take the medication your doctor prescribed for you on a regular basis along with the Tylenol. An exception to this is if the prescribed medication is Tylenol #3. In this case you would only take the prescribed medication, and not the extra Tylenol. Decrease medication use as the pain improves.
  - Do not push yourself beyond your limits. Rest when you feel tired and uncomfortable.
  - If you find your exercises are painful, take pain medication, wait 30 minutes before exercising and decrease the number of repetitions of each exercise. You may want to take pain medication before having your staples taken out.
- After a knee replacement, it is important to continue range of motion exercises even if it is uncomfortable. It will feel better in time. If in doubt, talk with your physiotherapist and/or surgeon.
  - Distract yourself from pain (i.e. listen to music, visit with friends, write letters, watch TV, etc.)
  - Use relaxation exercises such as breathing exercises. A warm shower may help you if your staples are out and there is no drainage from your incision.
  - Lie down, elevate your limb and place an ice pack wrapped in a towel on the painful area for 15 minutes up three times a day. A packet of frozen vegetables wrapped in a towel works well too.
  - Think positively. You will become more and more comfortable with time.

### Notify your family doctor immediately if you have:

- **a sudden severe increase in pain in your new joint pain or aching in your calves, redness of the calf, and/or excessive swelling of affected limb**
- **shortness of breath or chest pain**

***IF UNABLE TO CONTACT DOCTOR, GO TO THE EMERGENCY DEPARTMENT or COMMUNITY NURSING STATION.***

## Swelling

If you have had hip or knee surgery, you can expect to have some swelling in your leg. To help reduce the swelling, raise your legs whenever possible or do the foot pumping exercise you learned in the hospital, **apply ice and avoid sitting for long periods. Pump your feet and ankles to keep your circulation going.**

## Constipation

Constipation is the biggest problem for people taking Morphine, Oxycodone, Dilaudid or Codeine. Take a preventative approach: drink plenty of fluids, eat a high fibre diet including bran and prunes and take laxatives as needed.

Fiber supplements such as Fruit Lax or 'Get up and Go cookies' bulk up the stool making it easier to pass through the bowels.

Senna tea, Senakot tablets or glyssennid tablets help the stool move along through the bowel. Glycerine or Dulcolax suppositories will help to clear the lower bowel. It is important to follow instructions for your medications carefully to avoid side effects. Ask your doctor, nurse or pharmacist if you have any questions. See your doctor if you experience ongoing problems with constipation, nausea and vomiting.

## Other medical or dental procedures

It is very important that you tell your dentist and other medical practitioners if you have had a joint replacement. Before you have procedures done, such as a minor surgery or dental work, you may be put on antibiotics to prevent getting an infection in your new joint. You will not need antibiotics for a dental cleaning.

## Anemia (low blood count)

Your hemoglobin may be low after surgery. It is recommended that most people take iron pills for the month after surgery. Talk to your family doctor about this.

## Follow-up with Surgeon

Your surgeon will see you in follow-up when they are next in Whitehorse.

## Physiotherapy

You will be discharged from the hospital with a home exercise program. Continue to do these exercises as prescribed by the physical therapist until you begin therapy in an outpatient clinic, private practice clinic or with a homecare therapist. Your rehabilitation program may last 8 weeks or more depending on your progress. The emphasis will initially be on regaining range of motion. Later your program will include exercises to strengthen the muscles supporting your joint and improve your walking pattern.

Your balance and joint awareness will initially be poor after the surgery. Some exercises will help to restore your confidence in your new hip and decrease your risk of losing your balance or falling.

Whenever possible, the exercises will be functional and designed to address your individual self care, home care, mobility and leisure activity needs. If you have concerns about your ability to do specific daily activities, talk to your therapist.

### General Therapy Guidelines

- do the exercises daily or as prescribed by your therapist.
- use your walking aid and assistive devices until your therapist or surgeon tells you differently.
- gradually increase your walking distances during the initial six weeks.
- increase or progress your exercises when advised by your therapist.
- notify your therapist if any exercises increase your joint pain or stiffness.

## Daily Activity Guidelines

There are many assistive tools and movements that will make your daily activities easier and safer after joint replacement surgery. Follow these suggestions for at least 3 months after total hip replacement unless advised otherwise by your surgeon or therapist.

### Standing and Sitting

#### To stand up....

- move yourself to the front edge of the chair or toilet and keep your operated leg straight in front of you
- slide your other foot back slightly and lean forward slightly while pushing yourself up using the arm rests, grab bars or other secure surface
- make sure you feel steady before starting to walk

#### To sit down....

- back up until you feel the back of your legs against the edge of the chair or toilet
- slide your operated leg forward, lean forward slightly and reach back for the arm rests, grab bars or other secure surface
- lower yourself slowly sliding your operated leg in front. It may be easier to stand to use toilet paper to prevent too much bending and twisting at the hips.



### Mobility guidelines

Depending on the type of joint replacement you had and preferences of your surgeon, you will be given guidelines on how much weight you can place through your leg and what type of walking aids to use.

If you have had a total hip replacement, sit on seats that are at least level or higher than the top of your knees.

## Going up and down stairs

See more detailed information on crutch fitting and safe crutch use on pages 93 and 94.

### To go up stairs....

- hold onto the railing with one hand and put the crutches or cane in the other hand
- step up with your good leg and follow with your operated leg and walking aid
- if there is no railing, use a crutch under each arm or the cane on your non-operated side
- put your weight on the walking aid and step up with your good leg straighten your good leg and bring the walking aid and your operated leg up together



### Remember

*Up with the good,  
down with the bad.*



### To go down stairs....

- hold onto the railing with one hand and place your crutches or cane on the stair below
- step down with your operated leg and follow with your good leg
- if there is no railing, use a crutch under each arm or the cane on your non-operated side
- place the walking aid on the stair below and follow carefully with the operated leg
- put your weight on the walking aid and step down with the good leg

\* After 3 months, you may be able to go up and down the stairs using alternating legs. Some people use the above methods long after their surgery as they feel more stable and safe. Start with your non-operated leg when going upstairs. Start with your operated leg to go downstairs.

## Bathing

### To use the shower ....

- if you have a walk-in shower, place a secure high shower chair or stool in your shower stall
- back up to the edge of the seat and reach back for the seat with one arm while you slide your operated leg forward and sit down slowly
- use a hand held shower attachment
- dry off as best as possible before getting out of the shower
- use a non-slip bath mat inside and outside of the shower stall to prevent slipping on the wet surface
- use a regular walker to get into and out of the shower
- use a long handled device for washing your lower legs

### To use the bathtub....

- use a secure raised bath board or tub transfer bench, a hand held shower attachment and long handled aids
- back up to the edge of the seat and reach back for the seat with one arm while holding onto a grab bar or other secure surface with the other hand
- sit down slowly sliding your operated leg forward and slide back on the seat
- Lift legs over the side of the tub

*\* Have someone help you with bathing for the first while so that you are safe and comfortable. If you have questions about the set up of your shower or tub, or the installation of safety grab bars, please ask a rehab therapist in the hospital or at home care.*

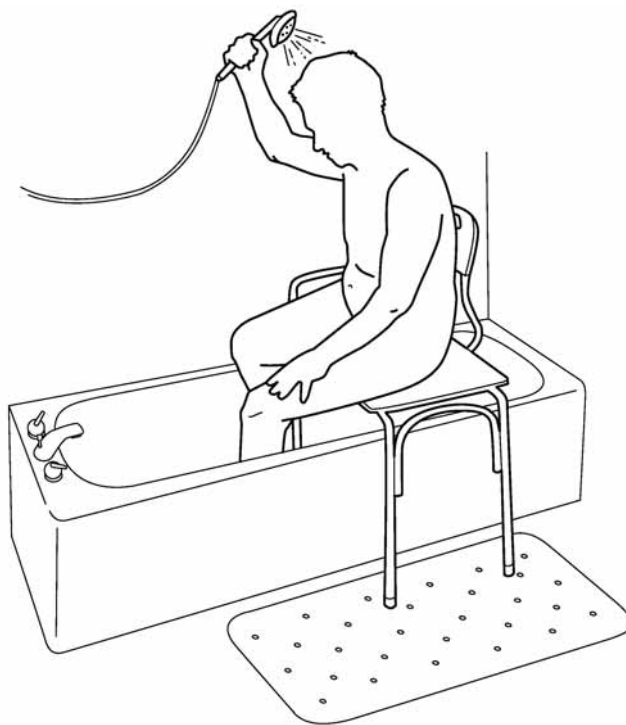

## Getting dressed

- sit on a high bed or firm chair with arm rests
- with your operated leg straight ahead of you, use a long-handled reacher, sock aid or shoe horn to put on your socks, pants and shoes
- you will be expected to get dressed in the hospital with these tools before going home so that a rehab therapist can give you tips if you are having difficulty



## Sleeping

- check that the top of your mattress is level with or above your knees. follow the guidelines for sitting and standing to get on and off your bed safely
- Put one large pillow between your knees and another between your ankles when sleeping on your back or your side
- If you have had a hip replacement, use a pillow between your knees to prevent your operated leg from crossing the middle of your body.



## Getting in and out of a car

- have the car parked well away from the sidewalk or curb so you have room to move
- if you are going home in a higher vehicle, you may need a footstool to get into and out of the vehicle
- move the front passenger seat back as far as possible and recline the backrest
- back up to the seat and place one hand on the dash board and the other on the back of the seat
- lower yourself slowly and slide back across the seat until you can comfortably swing your legs into the car
- use a firm, raised cushion with a smooth surface on the car seat if you find the seat is too low
- reverse this process to get out of the car and have your walker or crutches ready when you stand up



If you have concerns about your car transfer - discuss this with your therapist before leaving the hospital.

## Resuming sexual activity

Resume sexual activity when you are comfortable. This is often around 4 to 6 weeks after surgery. Some changes may be necessary to avoid pain or placing the new hip in a position of possible dislocation. Care must be taken in the first 3 weeks to protect the incision so that it will heal properly.

### After Hip Replacement

- You must maintain hip precautions for 3 months during all daily activities, including sexual activity.
- Think about how you will maintain your hip precautions of not twisting and not bending more than 90 degrees,
- You may need to consider trying some new positions. Talk to your partner.
- If you have questions or concerns about how to protect your new hip during sexual activity, talk to your occupational therapist, physiotherapist or surgeon.
- Visit the website:  
[www.aboutjoints.com](http://www.aboutjoints.com) for illustrations of sexual positions that maintain hip precautions.

## Living With Your New Joint

With good care and effort to protect your joint replacement from unnecessary stresses, your new joint should last at least 15 years. For the best possible outcomes, there are some long term guidelines for you to follow.



### Recreational Activity Guidelines

It is important to return to regular physical activity after your joint replacement. Light to moderate intensity activity done 4-7 days a week has many health benefits and will help to maintain good strength and mobility in your joint. Exercise can help you maintain a healthy weight which reduces the stress on your new joint so it lasts longer. Your activities should be low impact, allow for periods of rest and not cause joint pain. Choose activities that have a minimal risk of injury or falling and do not need excessive range of motion. Talk to your orthopedic surgeon and therapist about any sporting activities that you wish to do after your joint replacement.

#### Recommended Activities:

- walking, using a treadmill (shock absorbing footwear)
- swimming, water aerobics, deep water running
- recreational cycling, using a stationary bike
- traditional dancing
- no-impact aerobic dance (e.g. Joint Works)

#### Activities you may be able to do with caution:

##### (discuss with your surgeon)

- hiking easy trails
- downhill & cross country skiing (green & blue runs)
- golf (using a cart)
- modern dancing
- doubles tennis (avoid running & twisting)
- using a step machine or rowing
- repetitive lifting exceeding 20 kg
- lawn bowling (operated leg back)
- gardening / yard work

## Consulting your Family Doctor

Make an appointment with your family doctor if you have problems with:

- pain in your hip, knee or leg that lasts more than a few days
- you begin to limp or cannot bear weight through your operated leg
- your strength decreases and the operated hip feels “insecure”
- you notice a loss in range of motion in the hip or knee
- a painful “clicking” develops (painless clicking is common and of less concern)
- your operated leg suddenly feels shorter
- signs and symptoms of infection (see page 48)

They will refer you back to your surgeon if they have any concerns.

### **Activities to avoid:**

- running, jogging
- jumping (skipping rope)
- singles tennis, badminton, squash
- skating (inline and ice)
- contact sports (football, soccer, hockey)
- high impact sports (basketball, volleyball)
- horseback riding
- waterskiing

## Avoiding Falls

Joint replacement surgery will affect your leg strength, balance and joint awareness. You will be at greater risk for tripping and falling. To avoid falls, follow the suggestions listed under “Getting your home in shape” on page 38 and the following guidelines:

- wear non-skid, supportive footwear at all times
- use handrails when available, especially on stairs
- do not lean against unstable furniture
- know if the side effects of your medications can cause drowsiness or dizziness
- wear your eye glasses if needed
- always get up slowly after sitting or lying down and ensure you have your balance before taking a step

## Driving a Car

Driving needs enough hip flexion to sit comfortably and good muscle for braking and accelerating. In general, driving your vehicle within 6 weeks of your surgery is not recommended. This will vary based on the type of car (standard vs. automatic) and whether the right or left leg was operated on.

After a **left knee replacement** you can start driving an automatic when you are comfortable getting behind the wheel-usually 2-3 weeks. With a standard car, wait 6-8 weeks. With a **right knee replacement**, do not drive either a standard or automatic for 6-8 weeks.

Hip - Not recommended for a minimum of 6 weeks because the car seat brings the hip over 90° of upward bend.

Ask your family doctor about your readiness to start driving again. Avoid sitting in a car greater than 2 hours at a time after your joint replacement.

## Airport Metal Detecting Devices

Your new joint may set off metal detecting devices in airports and some buildings. The sensitivity of these devices varies and your implant is unlikely to set off most modern devices. Tell the security officer that you have a joint replacement and a hand held wand will be passed over your hip or knee area. Ask your doctor for a letter stating that you have a joint replacement if you are concerned about this when travelling.

## Pregnancy

Young women who have undergone a hip replacement may have some concerns around becoming pregnant and the extra strain this will put on the joint. Keeping your weight gain to the recommended 25-30 pounds and using a cane in the later stages of pregnancy may help to reduce some of the stress placed on your hip. Following the general activity guidelines such as avoiding squatting and sitting on low surfaces is especially important during this time. Restricted hip movement may make natural delivery more difficult.

# Yukon Resources

Important Contact Phone Numbers

Community Contact Information

Private Physiotherapy Clinics

Medical Equipment for Purchase or Rent

Exercise Facilities in Whitehorse

Pre-Hab Education

Pre-Op Education

Where to get Equipment?

Transportation

Out of Territory Travel - Claiming Your Expenses

Non-Insured Health Benefits (NIHB)

Accommodation near a Hospital



# Yukon Information for Total Joint Replacements

<b>Important Contact Phone Numbers .....</b>	<b>76</b>
<b>Community Contact Information .....</b>	<b>76</b>
Homecare	
Red Cross Medical Equipment Loans Service	
<b>Private Physiotherapy Clinics .....</b>	<b>77</b>
<b>Medical Equipment for Purchase or Rent .....</b>	<b>77</b>
<b>Ambulatory Aids Only .....</b>	<b>77</b>
<b>Exercise Facilities in Whitehorse .....</b>	<b>78</b>
<b>Other Programs.....</b>	<b>78</b>
<b>Get Your Body In Shape - “Use it or Lose it” .....</b>	<b>79</b>
<b>Pre-Surgery Information for Total Hip &amp; Knee Patients .....</b>	<b>80</b>
Pre-Hab Education Sessions	
Pre-Op Education Sessions	
<b>Knee Surgery in Whitehorse.....</b>	<b>81</b>
<b>Knee Surgery - Equipment.....</b>	<b>81</b>
<b>Knee Surgery outside the Territory .....</b>	<b>82</b>
<b>Hip Surgery .....</b>	<b>83</b>
<b>Hip Surgery - Equipment .....</b>	<b>84</b>
<b>Where to get Equipment? .....</b>	<b>85</b>
<b>Transportation .....</b>	<b>86</b>
<b>Out of Territory Travel - Claiming Your Expenses .....</b>	<b>87</b>
<b>Accommodation near a Hospital.....</b>	<b>89</b>
<b>AMBULATORY AIDS.....</b>	<b>91</b>

## *Important Contact Phone Numbers*

Family doctor .....	_____
Specialist's Clinic .....	393-8856
WGH Therapies Department .....	393-8963
(Physiotherapy and Occupational Therapy)	
Handy Bus .....	668-8394
Homecare .....	667-5774
Red Cross Loans (MELS) .....	456-7359
(See below for more information)	

## *Community Contact Information*

### **Homecare**

Kluhini Building **667-5774**  
3168-3rd Ave  
Whitehorse, YT

### **Red Cross Medical Equipment Loans Service**

(MELS) **456-7359**  
6 Hospital Road  
(at the far left of the Thomson Center beside the parking lot)  
Whitehorse, YT  
Y1A 3H7

- You must have a prescription from your doctor, physiotherapist or occupational therapist to obtain the equipment.  
The Red Cross Medical Equipment Loan Service (MELS) is run by volunteers and is open by appointment only. Call and leave a message. A volunteer will call you to arrange a time to pick up the equipment.

## *Private Physiotherapy Clinics*

### **Barbara Robinson Physiotherapy**

128F Copper Road, 2nd floor  
Whitehorse, YT

**456-7415**

### **Joanne Baines Physiotherapy**

**668-6080**

### **Physio Plus**

Canada Games Center  
200 Hamilton Blvd,  
Whitehorse, YT

**668-4886**

### **Whitehorse Physiotherapy**

508 Main St.  
Whitehorse, YT

**667-2138**

## *Medical Equipment for Purchase or Rent*

(including ambulatory aids)

### **Alpine Health Supplies / Medichair Yukon**

Horwoods Mall  
121-1116 1st Ave  
Whitehorse, YT

**393-4967**

- they have Total hip and knee small equipment packages-reachers, sock aids etc

### **Northern Hospital Supplies**

4200 4th Ave, corner of 4th and Ogilvy  
Whitehorse, YT

**668-5083**

## *Ambulatory Aids Only*

### **Medicine Chest Pharmacy**

**668-7000**

### **Shoppers Drug Mart**

Main Street  
Qwanlin Mall

**668-2485**

**667-6633**

### **Wal-Mart**

**667-2652**

*See a complete listing of all ambulatory aids at the back of this booklet*

## **Communities**

- The nursing station may have some of this equipment. Please check with them before you go for surgery.

## *Exercise Facilities in Whitehorse*

### **Canada Games Center**

(info line)

200 Hamilton Blvd (reception)

Whitehorse, YT

[www.canadagamescenter.whitehorse.ca](http://www.canadagamescenter.whitehorse.ca)

**667-4386**

**668-8360**

### **Better Bodies**

122 Industrial Rd

Whitehorse, YT

**633-5245**

### **Curves** (women only)

102A-100 Main St

Whitehorse, YT

**393-3443**

### **Peak Fitness**

95 Lewes Blvd

Whitehorse, YT

**668-4628**

## *Other Programs*

### **Tai Chi**

[www.taichi-yukon.ca](http://www.taichi-yukon.ca) for information on classes.

### **Pilates**

Northern Lights School of Pilates

66 River Ridge Lane

Whitehorse, YT

email: [nlightspilates@aol.com](mailto:nlightspilates@aol.com)

**456-4356**

### **Barbara Robinson**

128F Copper Road, 2nd floor

Whitehorse, YT

**456-7415**

### **Shanti Yoga**

2-404 Hansen St

Whitehorse, YT

[www.shantiyogayukon.ca](http://www.shantiyogayukon.ca)

**668-5055**

### **Yoga at the Alpine**

Alpine Bakery

411 Alexander St.

Whitehorse, YT

[www.yogayukon.ca](http://www.yogayukon.ca)

- Various classes-see notice board outside the bakery for information

## Essential Guide to Services in Whitehorse

- Provides information about a wide variety of services in Whitehorse including: Health and Support and Sports and Leisure  
[www.city.whitehorse.yk.ca](http://www.city.whitehorse.yk.ca)

### *Get Your Body In Shape - "Use it or Lose it"*

For a speedy recovery you need to be in good physical shape before surgery. That means getting physically prepared for your surgery.

You will need to rely on your arm strength for the first few days after surgery so building up your arm strength is important.

- See a community physical therapist
  - Talk to fitness trainer in the local gym
- Avoid exercise that increases the pressure on your damaged joint like jogging, hiking or the Stair-Master and try to keep your activities pain-free. Water may be one of the most comfortable ways to exercise.

### Canada Games Center Pool

(contact the pool for specific times)

667-4386

[www.canadagamescenter.whitehorse.ca](http://www.canadagamescenter.whitehorse.ca)

- Specific pool classes for those with Arthritis- "Oh My Aching Joints" started in 2009
- Post Operative Joint Replacement pool classes may be offered in late 2009.
- Aquafit classes -Regular or Senior's
- Pool Running classes
- Lane Swimming

### Other Options

The pool offers a "Physio Time" when it is not as busy

### Local Gyms or Wellness Center at Canada Games Center

There is equipment for cardiovascular fitness and free weights, exercise balls etc. Good options for patients awaiting total joint replacements are:

- Upper body weights and core strength exercises
- Stationary bike-upright or recumbent
- Elliptical machine/treadmill/walking track

### Communities

- There may be equipment such as stationary bikes, treadmills, weight lifting equipment in your community. Check with your local community center or school.

## ***Pre-Surgery Information for Total Hip & Knee Patients***

To prepare you for your surgery, your team at Whitehorse General Hospital has a comprehensive approach.

### **You see the Orthopedic Surgeon**

Once the surgeon has determined that you need a joint replacement, you will be put on a waitlist. Your surgery will either be done in Whitehorse or outside.

- The receptionist at the Specialist's Clinic has given you this booklet so you can start preparing for your surgery.
- You may be waiting for up to a year for the surgery but you can take this time to get in shape for it.

### **Pre-Hab Education Sessions**

The doctors, nurses, dietitians, physiotherapists and occupational therapists are very concerned that you are in good shape before your surgery. It helps you recover faster and makes their job easier too!

They offer free evening drop-in sessions once every 2 months. These will help you understand what you need to do to get ready for surgery. These sessions will help you PreHab-get in shape before your surgery through exercises and eating well. You will be given more information about the surgery, what to expect in hospital, as well as what equipment you need to have before leaving the hospital to start your post operative Re-Hab.

- To find out when the next session will take place, contact the therapies department at 393-8963.
- There will also be ads in the papers and on the radio giving you more information.

### **Pre-Op Education Sessions**

You must attend a Pre-op class offered at the Therapies Department. These classes are offered twice a month for all patients having total joint surgery either in Whitehorse or "outside". There will be a nurse, dietitian, physiotherapy and occupational therapist presenting information and small group sessions.

The class gives you more details about your surgery and what to expect. You will be taught how to use the equipment you will need to have at home and be given a Red Cross prescription for your equipment. You can also ask questions about any concerns you have. You may bring one support person to the class. Be sure to bring someone if you have difficulty writing or reading.

You should attend a class 2-4 weeks before your surgery.

Call Therapies at 393-8963 for information about the class. The surgeon's office will call you with your surgery date.

## *Knee Surgery in Whitehorse*

If your surgery is being done in Whitehorse you will be mailed a list of appointments that will take place about 2 weeks before your surgery. All are on the same day. The appointments take most of the day. Make a list of any questions or concerns you have so you can ask the health professional at your visit.

Appointments include:

- Pre-Operative Clinic
- Laboratory for bloodwork.
- Physiotherapy- for a specific assessment of your pre-operative status and information regarding your exercises in the hospital and at home as well as walking aids.
- Occupational therapy-for specific information about your home situation and how you will manage day to day activities as you recover.
- Radiology for a pre surgery x-ray.
- Anaesthetist for a pre operative consultation.
- You will have a pre-op visit with your surgeon the day before or the morning of your surgery.

## *Knee Surgery - Equipment*

### **Bring to the Hospital**

- Non-skid supportive footwear not too tightly fitting. Velcro or elastic shoelaces mean you don't have to bend over to tie the laces
- Walker /Crutches fitted to you.
- If it's winter you can buy safety tips for your crutches from a medical supply store.

### **Have at Home**

- Raised toilet seat (optional but helpful if you have a low toilet)
- Bath board, bath transfer bench or bath chair
- Long-handled reacher\* (optional)
- Long-handled shoe-horn\* (optional)
- Comfortable loose fitting clothes so you can get yourself dressed

\*these items are not loaned and you will need to buy them.

## *Knee Surgery outside the Territory*

- The surgeon's office will contact you by phone with the date of your surgery.
- Take a walker or crutches with you; the hospital will not supply them when you leave.
- If you are staying in Vancouver after your surgery, make sure you have a raised toilet seat, and other aids so you can be independent. The Accent Inn near Burnaby Hospital has fully wheelchair accessible rooms and standard rooms with a raised toilet seat and tub transfer bench available. Be sure to request one if you are staying after your surgery.
- You will need to be seen in the Pre-Op clinic before your surgery and you may need to see a doctor of Internal Medicine. Most people need to be there 4-5 days before their surgery.

## *Hip Surgery*

All hip surgery is currently done in hospitals outside the Yukon. The surgeon's office will phone you with a surgical date.

- If you know you will need surgery but don't have a date yet, call the Therapies Department and they will tell you when the next PreHab information sessions are (see page 80 for more information on these).
- Once you have a surgery date, you will need to arrange to attend a Pre-op Class (see page 80 for more information on this class.)
- When you are scheduled for surgery it is important to get prepared with the suggested equipment before the surgery. The hospital will supply a raised toilet seat for your inpatient stay and you can use one of their walking aides while you are there. You should take crutches or a walker with you on your trip out of territory in order to help you leave the hospital. Also bring a raised cushion, a reacher, sock aid and long handled shoe horn to help you dress yourself.
- The hospitals will have an information booklet similar to this one outlining more about the surgery. You will get this when you arrive at the hospital.
- Most people are seen in the Pre-Op clinic at the hospital where they are having their surgery about 4-5 days before their surgery.

## ***Hip Surgery - Equipment***

### **Bring to the Hospital**

- Non-skid supportive footwear not too tightly fitting. Velcro or elastic shoelaces mean you don't have to bend over to tie the laces
- Walker or Crutches fitted to you.
- If it's winter purchase safety tips for your crutches from a drugstore or medical supply store.
- Long-handled reacher
- Long-handled shoe-horn
- Comfortable clothes so you can get yourself dressed

### **Have at Home**

- Raised toilet seat
  - Bath board, bath transfer bench or bath chair
  - Sock aid\*
  - Long-handled reacher\*
  - Long-handled shoe-horn\*
  - Comfortable loose fitting clothes so you can get yourself dressed
- \*these items are not available for loan and will need to be purchased.

### **Hip and Knee Post Surgery Outpatient Physiotherapy**

- It is important to start physiotherapy about a week after you return to Whitehorse. You can attend the Therapies Department at Whitehorse General Hospital. A list of the local private clinics is located on page 77 of this booklet.
- Please call a clinic to book an appointment before you leave for surgery or as soon as you know your return date. Your surgeon will write a prescription for this after your surgery. Bring it and any other instructions you have.

### **Contacting your Family Doctor After Your Surgery**

- You will need to contact your family doctor to arrange an appointment to have your incision staples removed. This is done 12 to 14 days after the surgery.

## *Where to get Equipment?*

### **Red Cross Medical Equipment Loan Service (MELS)**

- They will loan medical equipment for up to 3 months, if available.
- You will need a referral and this can be obtained from the PT or OT at your pre-operative visit or from your family doctor.
- You must call to arrange a time to pick up the equipment.

### **Pharmacare or Chronic Disease Programs**

- If you are on either of these YTG medical benefit programs, equipment may be available through these programs.
- You will need a therapist to prescribe the equipment.

### **Equipment Rental or Purchase**

- You can rent or purchase equipment from Alpine Health or Northern Hospital and Rehabilitation Supplies (see page 91 for contact information), including smaller items like a reacher, sock aid or a cane. A complete list of stores supplying walking aides is listed on page 91.
- Sometimes you can be reimbursed for these expenses through your Extended Health Benefit Plan through your employer.

### **Non-Insured Health Benefits (NIHB)**

- If you belong to a Yukon First Nation, medical equipment can be provided via this program. You will need a doctor's prescription to obtain this.

*If you borrow equipment, please return it  
as soon as you are finished with it.  
Others may need it.*

## *Transportation*

After surgery you will not be able drive for a period of time. It is essential to arrange transportation to drive you home and to therapy/doctor's appointments.

### **Handy Bus**

**668-8394**

- You must fill out an application and have it signed by a doctor, physiotherapist, occupational therapist, or registered nurse.
- Once the application is approved, you must call to arrange Handy Bus services. The service is very busy so call ahead to book transportation.

### **Handicapped Parking Permit**

**668-8317**

- You must make written application for a Handicapped Parking Permit from City of Whitehorse Bylaw Services

## *Out of Territory Travel - Claiming Your Expenses*

### **If Yukon Medical is Covering your Surgery**

#### **Arranging Your Flight**

You need to see your Yukon doctor who will then submit a Medical Travel application. Patients are generally in hospital 4 days after hip surgery and 3 days after knee surgery. You will be contacted by a Medical Travel Officer who will arrange your flights.

You will be given a yellow subsidy form which you must have signed at each of your visits including hospitalization. See the attached sheet as an example.

Eligible subsidy starts on Day 2 of your travel. For example if you fly down on Sunday for an appointment Monday. You can claim expenses for the Monday but not the Sunday. You are covered for a maximum of \$75 per day. Your completed claim must be mailed or dropped off to Medical Travel. The address is on the top of the form.

#### **Changing Your Return**

If your return travel date changes for medical reasons, the nurse or social worker must contact Medical travel and inform them. If the change is made on a weekend, you must contact the airline to change your flight bookings. If the airline charges a change fee or an additional collection, you can submit a copy of the flight change which must show your name, date of travel, itinerary and cost of the change. If they charge you a penalty for that change it will be reimbursed.

If you chose to stay longer (but it is not medically necessary), you may need to pay an airline change penalty and you must pay all your own living expenses. If you wish to make personal changes to the reservation, please inform Medical Travel who will note the file, and then contact Air North to make the change that you must pay for. If you are flying with Air Canada, you can call the Travel Agency or Air Canada and you are responsible to pay for the costs to make a change. The flight back will be covered.

#### **Air Canada:**

**1-888-247-2262**

#### **Air North:**

**1-800-661-0407, 668-2228**

#### **Leaving the Hospital**

You must phone and arrange for your own taxi to the airport if you are heading back to the Yukon after discharge from the hospital.

#### **For Federal Government Employees or WCB**

Please contact your health care plan or WCB worker to find out more about your coverage.



**Medical Transportation Out Of Territory  
Information for First Nations and Inuit Clients**

**Eligibility for Assistance**

To receive assistance with medical transportation through Health Canada's Non-Insured Health Benefits (NIHB) Program, a person must be a registered Indian as per the Indian Act; an Inuk recognized by one of the Inuit Land Claim organizations, or an Inuit with a letter of recognition from one of the Inuit Claim organizations and in receipt of a long form birth certificate; and, are currently registered or eligible for registration under a provincial or territorial health insurance plan.

**Physician Referral to Out Of Territory Medical Services**

Once your physician has referred you out of territory for medical services, his/her office will follow up with you directly to confirm the date, time and location for your appointments. Please advise your doctor's office that you are eligible for NIHB Program services and they will forward a request for travel to the NIHB Program office. All escorts must be preauthorized by NIHB Program and require physician recommendation. Please contact the NIHB Program office for more information.

**Travel Arrangements**

A NIHB Program analyst will contact you to discuss your medical travel request including any special considerations for travel arrangements. The analyst is responsible for arranging your flight and accommodations and will provide you with vouchers for taxis and meals. The analyst will provide you with an "Appointment Attendance" sheet which must be signed by a medical professional at each appointment and/or during your hospital stay. Your return flight will be booked after the medical professional has contacted the NIHB Program Office to let them know you are able to return home.

**Medical Equipment and Supplies**

Prior to leaving the Territory, you may be required to obtain necessary equipment and/or supplies for your post-treatment care. Note that you may be required to bring this equipment with you when leaving the Territory. The medical professional will provide you with a prescription, which should be sent to the NIHB Program office for processing as soon as possible.

**For more information, please contact:**

<b>For Clients from:</b>	<b>Contact Information</b>
Beaver Creek, Destruction Bay, Carmacks, Haines Junction, Ross River, Teslin and Northwest Territories	Toll Free: 1-866-362-6717
Carcross, Dawson City, Faro, Mayo, Old Crow	Toll Free: 1-866-362-6718
Atlin, Pelly Crossing, Watson Lake, Whitehorse, Ta'an, Out-of - Territory	Toll Free: 1-866-362-6719



## *Accommodation near a Hospital*

### **Burnaby Hospital**

#### **Accent Inn:**

3777 Henning Drive,  
Burnaby, B.C. V5C 6N5

**604-473-5000**

Located 1km from hospital with a free shuttle to the hospital and within Burnaby.

You must take a taxi from the airport to the hotel.

- Be sure to request a raised toilet seat and tub transfer bench if you are discharged and are returning to the hotel post operatively. They do not supply walkers, wheelchairs, or crutches-you must bring your own walking aid, reacher, sock aid etc.

#### **Medivan**

**877-222-2031**

Van service to the airport that provides full assistance to patients being discharged.

Carrying luggage, taking patients into the airport.

Cost is \$90 +GST

Needs 1-2 days notice

### **UBC Hospital**

#### **West Coast Suites:**

5959 Student Union Boulevard  
Vancouver, BC, Canada, V6T 2C9

**1-888-822-1030**

One bedroom suites close to UBC hospital complete with kitchenette

### **Vancouver General Hospital**

#### **Shaughnessy Village Bed and Breakfast**

1125 West 12th Ave.  
Vancouver B.C. V6H3Z3

**604-736-5511**

Rooms or suites include breakfast, refrigerator, microwave.

Restaurant. 5 mins from hospital

### **VGH Center for Patients**

Jim Pattison Pavilion,  
1st Floor, Rm 1861  
899 West 12th Ave.  
Vancouver BC V5Z 1M9

[www.vch.ca/centreforpatients](http://www.vch.ca/centreforpatients)

## **University of Alberta Hospital**

### **Outpatient Residence:**

North-east corner of 114 St and 83 Ave  
8440 - 112 Street  
Edmonton, Alberta, T6G 2B7

**780-407-6593**

Outpatients take priority booking but visitors may be accommodated depending on room availability.

## **Foothills Hospital**

**403-289-0211**

## **Calgary North Thriftlodge**

2304 16th Ave NW  
Calgary, Alberta T2M 0M5

# AMBULATORY AIDS

ALPINE HEALTH SERVICES		121-1116 1st Avenue (Horwoods Mall)		phone (867) 393-4967 fax (867) 393-4870
		RENT	BUY	NOTES
Canes		Visa Deposit plus \$10/week	\$25	Will deliver Would like lots of info Saturday not as easy sometimes
Crutches	Wood	Visa Deposit plus \$15/month	Not available	
	Aluminum	Not available	\$40	
Walkers	Standard	\$15/week	\$90 and up	
	Wheeled	\$35/week	\$395 and up	
MEDICINE CHEST PHARMACY		406 Lambert Street		phone (867) 668-7000 fax (867) 633-3642
		RENT	BUY	NOTES
Canes		\$25 Deposit plus \$5/month	\$25 and up	Will deliver Not Saturdays
Crutches	Aluminum only	\$40 Deposit plus \$5/week	\$40 and up	
Walkers	Standard	\$50 Deposit plus \$15/month or \$5/week	\$74 and up	
NORTHERN HOSPITAL SUPPLIES		508 Main Street		phone (867) 668-5083 fax (867) 668-6155
		RENT	BUY	NOTES
Canes		\$10/week	\$28 and up	Will deliver Not Saturdays
Crutches	Wood or Aluminum	Visa Deposit plus \$20/week	\$70 and up	
Walker	Standard Wheeled	\$20/week \$25/week	\$75 and up \$320 and up	
SHOPPERS DRUG MART		100-211 Main Street phone (867) 667-2485 fax (867) 668-2778		OR 2-203 Ogilvie Street phone (867) 667-6633 fax (867) 668-6627
		RENT	BUY	NOTES
Canes		\$10/week plus \$6/week	\$15.99 and up	Could deliver, but not done normally
Crutches	Metal	\$42 Deposit plus \$7/week	\$24.99 and up	
Walkers		None	None	
WAL-MART		Quartz Road & 2nd Avenue		phone (867) 667-2652 phone (867) 667-7641
		RENT	BUY	NOTES
Canes		NO RENTALS	\$10.36 and up	
Crutches		NO RENTALS	\$28.63 and up	
Walkers		NO RENTALS	\$58.76 and up	



## Walking with Crutches/Canes or a Walker

### Sit To Stand

- Grasp both crutches in one hand.
- Push up on chair arm with other.
- Cane/walker—one hand on cane or walker

Push up on chair arm with other hand  
Stand tall.

Swing crutches under your arms one  
at a time.

Your surgeon will tell you if you can  
take weight on your surgical leg.

Most people can.



### Down Stairs

- Surgical leg and crutches/ cane go  
down first.
- Unless you are given different  
instructions you may take weight on  
your surgical leg as tolerated.
- You can't use a walker on stairs.

### Up Stairs

- "Good go Up"
- Good leg up step.
- Crutches/cane and surgical leg follow.
- Unless you are given different instructions you  
may take weight on your surgical leg as tolerated.



## Measuring Crutches

- Stand tall, arm by side.
- Measure 3 fingers between crutch top and armpit.
- With arm hanging down cross bar at wrist crease.
- Walkers and canes-set handle height at wrist crease.



## Winter Safety Tips



- Winter ice gripper flipped up out of the way.



- Ice grips flipped down for use.
- Available for purchase at stores where crutches are sold.